

UL
c
E301099

Safe, Fast and Easy to install with the ELED POWER
Installation simple et rapide avec le système de connexion
ELED POWER



SÉRIE LUXSTRUT 9500
FEUILLE D'INSTALLATION
LUXSTRUT 9500 SERIES
INSTALLATION SHEET

1. Installation

1. Appuyer et coller le ruban DEL (suivre les guides 10 mm ou 14 mm) sur le rail.

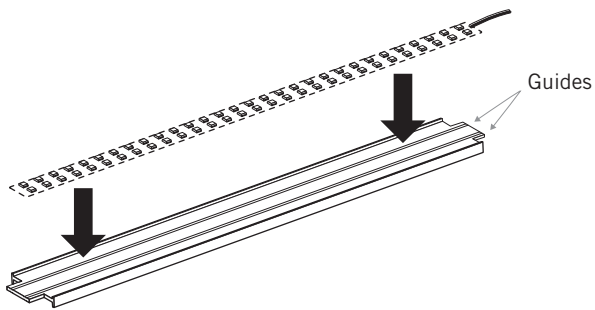

2. Glisser le rail à l'intérieur de la barre profilée, à l'hauteur choisie.

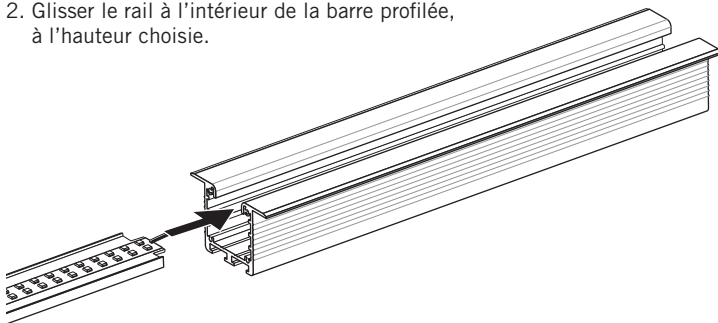

1. Installation

1. Press and glue the LED Strip Tape onto the rail (follow 10 mm or 14 mm guides).

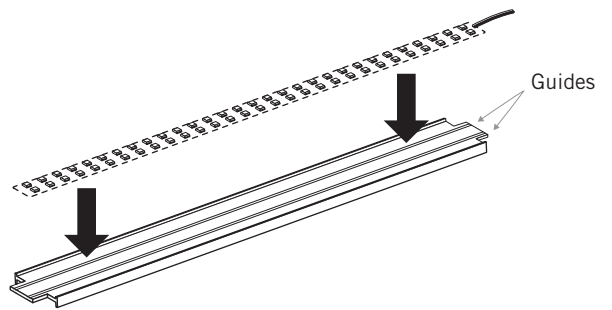

2. Slide the rail into the profiled bar, at the chosen height slot.

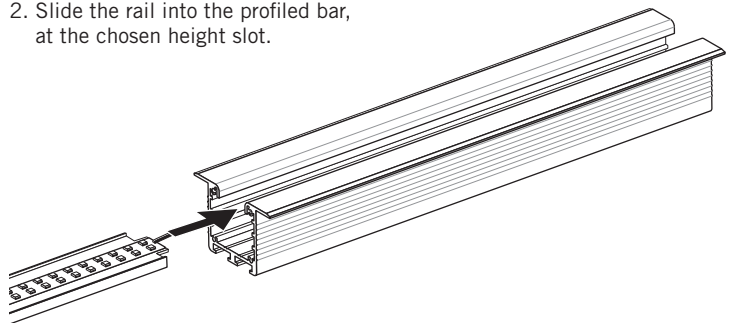

1. Installation

3. Mettre la lentille en place.

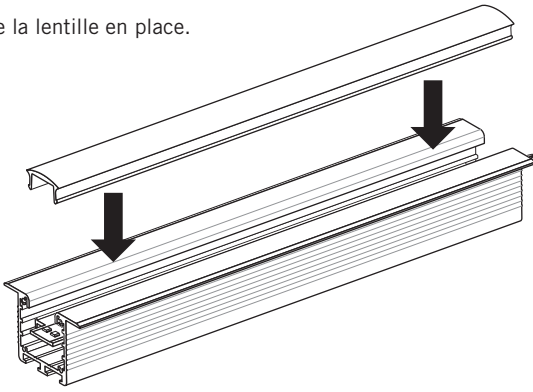

4. Pour une installation suspendue, glisser les supports de fixation, puis reserrer les vis.

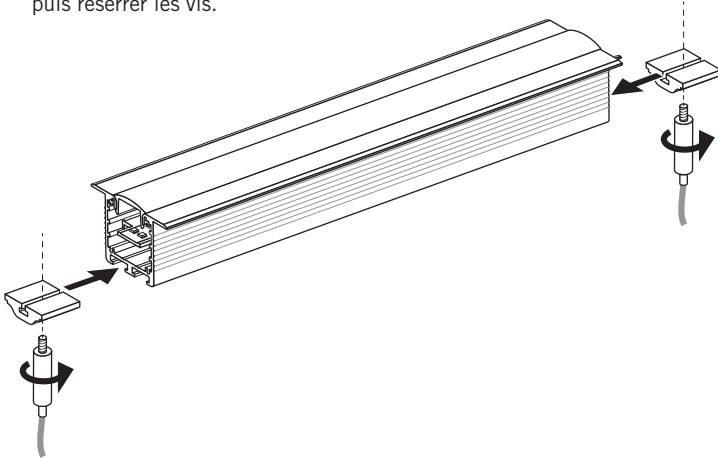

5. Glisser les embouts en place. Installer le luminaire à l'endroit choisi. Pour une installation encastrée, s'assurer que le trou est doté d'ancrages appropriés.

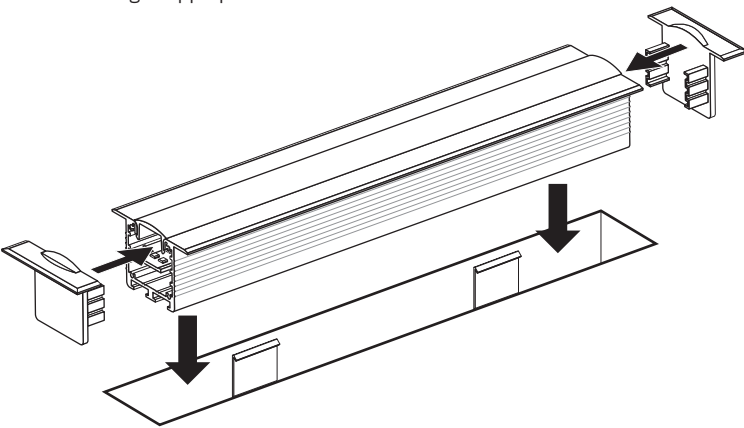

Mise en garde

1. Utiliser seulement des composants Certifiées Classe 2 n'excédant pas 30VCC ou 15VAC lors d'une installation dans un endroit mouillé ou 60VCC ou 42.4V ca maximum lors d'une installation dans un endroit sec ou humide.
2. Ne pas dépasser 5 ampères pour respecter les normes classe 2.

CLASSE
2

100W
MAX

4 AMP MAX
↓ 24V

5 AMP MAX
↓ 12V

1. Installation

3. Clip the lens into place.

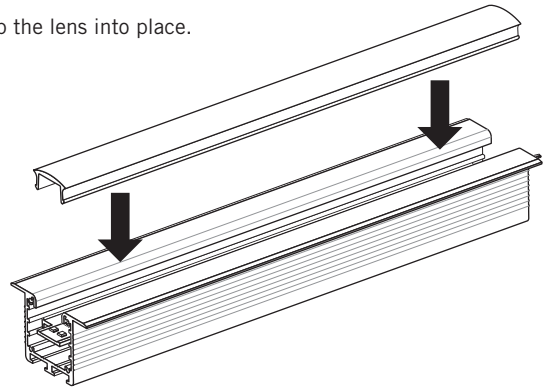

4. For a suspended installation, slide in the suspension brackets, then tighten the bolts.

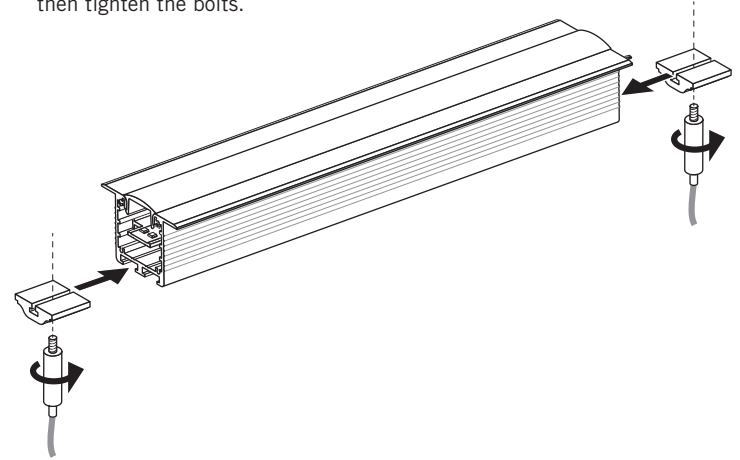

5. Slide the encaps into place. Install the light fixture at the chosen location. For a recessed installation, use appropriate fastening anchors in the hole.

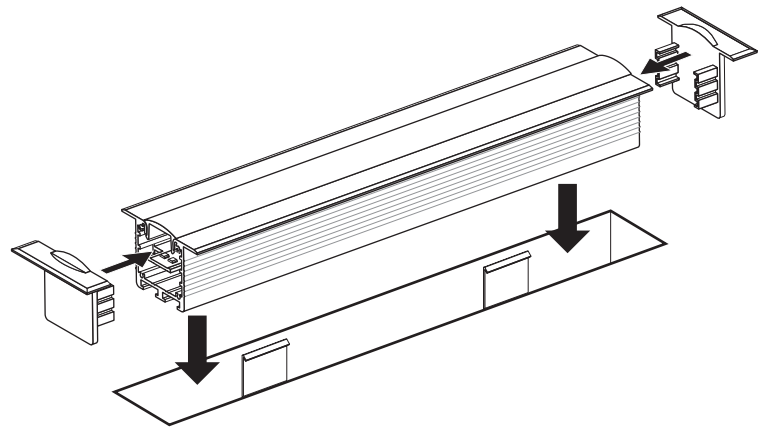

Warning

1. Use only Class 2 rated components not exceeding 30VDC or 15VAC when installing the outline lighting in wet locations or 60VDC or 42.4V peak ac when installing the outline lighting in a dry or damp location.
2. Do not go over 5 amps to match class 2 requirements.

CLASS
2

100W
MAX

4 AMP MAX
↓ 24V

5 AMP MAX
↓ 12V